



Neo-BLOT-Mini-XL
NeoBlot 4-gel Mini
Vertical Blot

NB-12-8002B

Neo-BLOT-Mini-XL
NeoBlot 4-gel Mini Vertical Blot
#Cat: NB-12-8002B



Unpacking remarks

1. Neo-BLOT-Mini-XL is packaged by the imported corrugated paper with clean appearance outside and quality environmental friendly lining inside. The product label is labeled on the outer package. Please check the outer package carefully to make sure it is in the best condition, please contact us in case of any damage.

2. Packing list

Item & Type	Code	Accessories	Qty	Unit	Description
Neo-BLOT-Mini-XL 4-gel Mini Vertical Blot	NB-12-8002B-09	Blot Frame for Neo-BLOT-Mini-XL	1	piece	With platinum electrode, used to hold transfer clip
	NB-12-8002B-10	Blot Clip for Neo-BLOT-Mini-XL	4	piece	100*75mm, 2 connected pored plate
	NB-12-8002B-11	Sponge for Neo-BLOT-Mini-XL	10	10pcs/ bag	For wrapping gel and nitrate membrane
	NB-12-8002-04	Cooling Unit	2	piece	For cooling, usage rotation available
	NB-12-8002B-12	Upper Lid (with cable) for Neo-BLOT-Mini-XL	1	piece	Lid with power cable
	NB-12-8002B-13	Lower Lid for Neo-BLOT-Mini-XL	1	piece	Cell bottom
	NB-12-8001-12	Support for glass plate	1	piece	Able to put 14 pieces of glass plates
	NB-12-8001-13	Multi-purpose support for centrifugal tube	1	piece	Able to put 91 pieces of centrifugal tubes with different specifications
		Manual	1	piece	
		Packing List	1	piece	Detailed accessories

3. To insure the best performance and optimize the condition of experiment, please read this instruction manual carefully to get acquainted with every component and function of electrophoresis system. The correct operation is required to avoid a damage and prolong the usage of the electrophoresis.

4. It is recommend that the customer use the neutral detergent to cleanse all the components and then to cleanse them again by distilled water before using Neo-BLOT-Mini-XL

Content

Chapter 1 General Instructions	1
1.1 Introduction.....	1
1.2 Technical specification	1
1.3 Safety Instructions.....	2
Chapter 2 Installation and preparation for Neo-BLOT-Mini-XL.....	3
2.1 The assembly of Neo-BLOT-Mini-XL.....	3
2.2 Preparation for blot.....	3
2.3 Acid transfer	5
Chapter 3 Condition for electrophoresis transfer	6
3.1 Guideline for buffer transfer and running condition	6
3.2 The cautions for electrophoresis transfer	7
3.3 Formula of buffer	8
Chapter 4 Procedure for optimizing condition of electrophoresis	10
4.1 Optimizing protein transfer.....	10
4.2 Optimize DNA and RNA electrophoresis.....	12
Chapter 5 Option of transfer membrane.....	13
5.1 Protein blot membrane.....	13
5.2 DNA and RNA blot membrane	13
Chapter 6 Trouble shooting	15
6.1 Electrophoresis transfer	15
6.2 Detection of immunological feature	18
6.3 Detection of protein	20

Chapter 1 General Instructions

1.1 Introduction

Neo-BLOT-Mini-XL is a part of Neo Biotech Mini Vertical Protein Electrophoresis System, which also contains Neo-PRO-Mini that running SDS-PAGE gel and Native-PAGE gel.

Neo-BLOT-Mini-XL accommodates 4 blot clips, uses for blotting protein and RNA sample in the polyacrylamide and agarose gel.

Cooling unit belongs to the standard accessories of Neo-BLOT-Mini-XL, which after being frozen to absorb the heat generated during the operation of blotting. The built-in cooling unit avoids the trouble of connection and the cost of installing the external cooling-recycling system. Other features include easy-to-use lock mechanism installed in gel clamp, gel clamp with color marker, direction positioning, special-designed plug-in-out mechanism. All these features make Neo-BLOT-Mini-XL a perfect electrophoresis system that is easy to use.

1.2 Technical specification

Electrophoresis core	Polycarbonate
Gel sandwich clamp	Polycarbonate
Electrophoresis electrode	Platinum wire (made from platinum ingot)
Buffer tank and upper lid	Polycarbonate
Cooling unit	Polyethylene and cold storage agent
Cell size	16 cm (L) x 12 cm (W) x 18 cm (H)
Gel clamp size	10.9 cm x 11.6 cm
Maximum gel size	8 cm x 9.6 cm
Buffer volume (with cooling unit)	850 ml
Buffer volume (without cooling unit)	650 ml

Cleanse:

Use the neutral detergent and warm water to cleanse the electrode, gel clip and buffer tank. Be careful to cleanse the electrode and avoid extending or breaking off the platinum wire. Do not use the abrasant and strong detergent to cleanse the instrument. Warm water is to rinse the fiber lining cushion and then make it clean by distilled water and ion-removing water.

Chemical reagent compatibility:

All the components of Neo-BLOT-Mini-XL should be kept clear of hydrochloric ether (such as chloroform), arene (such as methylbenzene, benzene) and acetone. The damage caused by organic reagent is not covered by guarantee.

1.3 Safety Instructions

Neo-BLOT-Mini-XL is powered by the external-connected direct current that must be isolated from the external-ground wire with the view to assure that the current is conducted through electrophoresis tank. All the Neo Biotech branded instruments meet such safety standard. The following are the maximum value regardless of what power supply is applied,

150V (direct current)	Maximum input voltage
40W	Maximum input power
50°C	Maximum temperature

The current is inputted via the upper lid, which supplies the customer with the safe-mutual lock. The current is disconnected when the upper lid is opened. Be sure to power off power supply before removing or opening the upper lid. Do not try to operate the instrument without upper lid.

Note: The safety standard is met from designing stage to manufacturing stage. It is safe to operate the instrument according strictly to the instruction manual. Do not mend or improve the instrument by any means. Otherwise, it leads the following result:

- The quality guarantee is valid.
- Damage the safety standard
- Cause the potential safety hazard.

Neo Biotech is irresponsible for and damage and loss caused by any improper usage intentionally and unauthorized improvement.

Chapter 2 Installation and preparation for Neo-BLOT-Mini-XL

2.1 The assembly of Neo-BLOT-Mini-XL

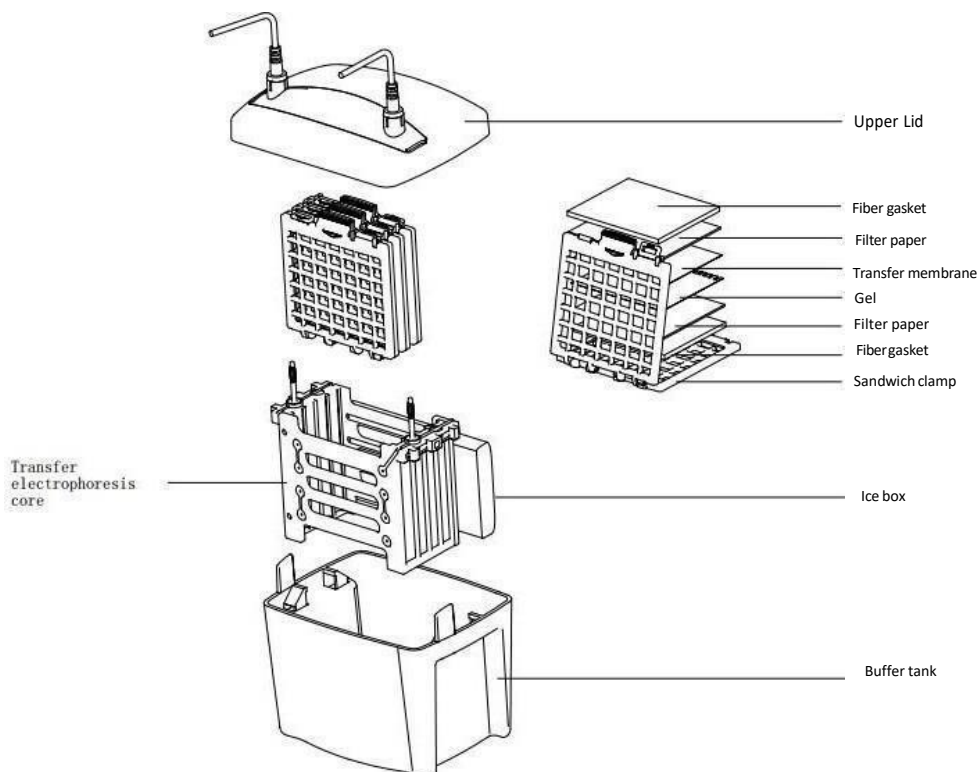

2.2 Preparation for blot

Put cooling unit into the refrigerator with temperature -20°C , and put it back after usage.

1. Prepare the buffer. (Please refer to formula mentioned in section 3.3, it is easy to diffuse the heat when the buffer is freeze to 4°C)

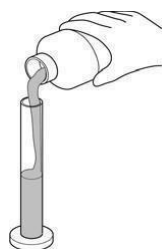

2. Cut the filter paper and membrane according to the size of gel, please wear the glove to avoid pollution. Equilibrate the gel and immerse the membrane and filter paper as well as the macroporous sponge (From 15 minutes to 1 hour, depended on the thickness of the gel).

3. Prepare the sandwich clamp and put on the clean desk with the black side downward. Put a ready-wet macroporous sponge on the black part of clamp. Put the wet filter paper on the macroporous sponge. Put the equilibrated gel on the filter paper (Remove the air bubble between the gel and filter paper). Put the

immersed membrane on the gel (Remove the air bubble between the membrane and gel). Put the filter paper on the membrane and remove the air bubble, add the transfer lining.

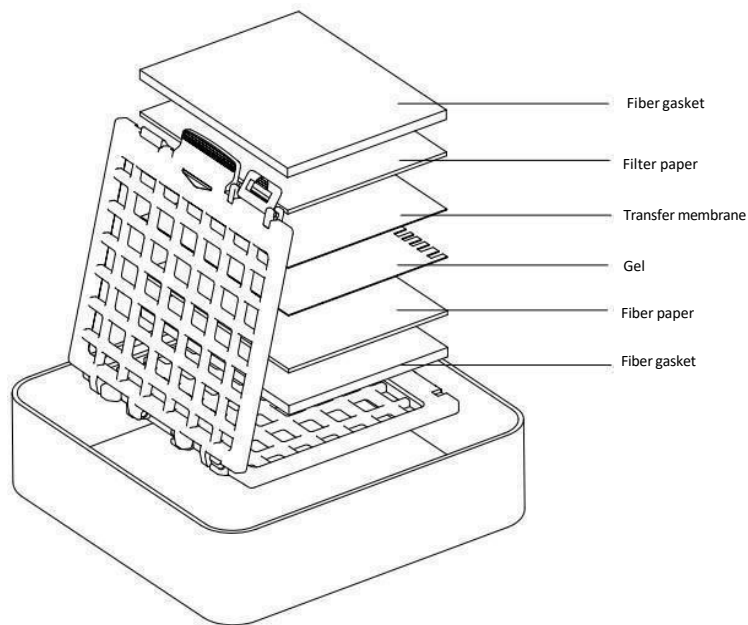

Note: In order to achieve the best blot result, it is key to remove the air bubble by glass bar stirring.

4. Tighten the clamp and do not move the gel and filter paper sandwich, then use the white sliding latch to lock the clamp.
5. Insert the clamp into the blot electrophoresis core, and repeat the process to make another sandwich gel.

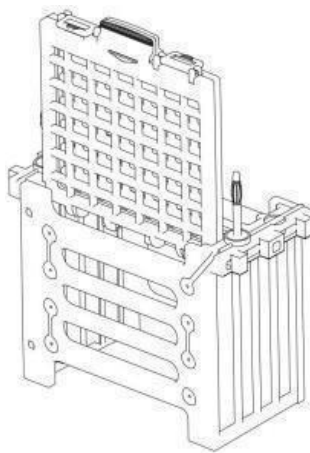

6. Put the cold cooling unit in the tank and fill up the tank by buffer.

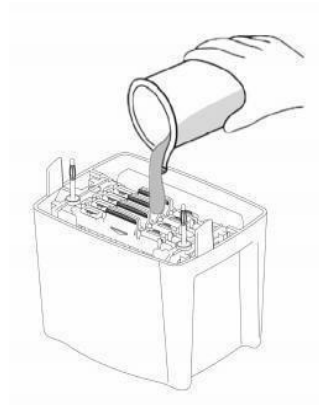

7. Put the stirring bar into the buffer to maintain temperature and equilibration of the ion strength, set the most suitable speed to distribute the ion evenly.

8. Close the safety lid and plug the power supply cable into power supply and start the blot. The setting of voltage and time for different buffer, please refer to the chapter 3.

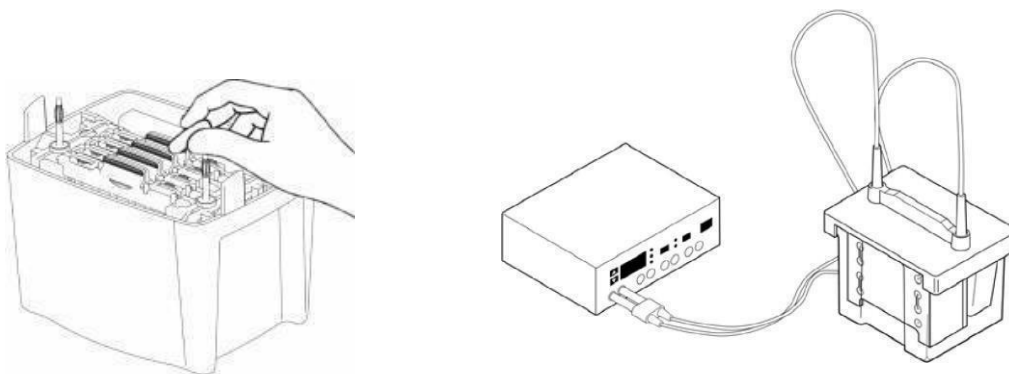

9. Disassemble the sandwich when the electrophoresis ends, take out the membrane and continue the next step. Use the neutral detergent to rinse the electrophoresis tank, blot clip, macroporous sponge, and then again use the ion-removing water to rinse.

2.3 Acid transfer

If the transfer is being done under acidic conditions, switch the position of the gel to the membrane and place the membrane on the cathode of the gel.

Under acidic conditions, the protein migrates to the opposite direction, the direction of negative electrode, do not reverse the electrode otherwise it may be damaged.

Chapter 3 Condition for electrophoresis transfer

3.1 Guideline for buffer transfer and running condition

The table 3.1 indicates the different power supply and time needed according to different buffer. The general rule is that shorter time needed, the higher voltage is. The cooling unit should be used during the process of electrophoresis.

Table 3.1 Guideline for buffer transfer and running condition

Buffer	Standard field strength transfer overnight	High field strength Distance of electrode is 4cm Transfer time 1 hour
SDS-PAGE Gels	Buffer A or B or C	Buffer A or B or C
A: 25 mM Tris, pH 8.3, 192 mM glycine, with or without 20% MEOH and .025%–0.1% SDS. B: 48 mM Tris, pH 9.2, 39 mM glycine, with or without 20% MEOH and .025%–0.1% SDS. C: 10 mM NaHCO ₃ , 3 mM NaCO ₃ , pH 9.9, with or without 20% MEOH and .025%–0.1% SDS.	30 V 90 mA	100 V 350 mA
DNA and RNA		
TAE: 20 mM Tris, pH 7.8, 10 mM sodium acetate, 0.5 mM EDTA TBE: 50 mM Tris, pH 8.3, 50 mM sodium borate, 1.0 mM EDTA	30 V 100 mA	80 V 500 mA
Native Gels		
25 mM Tris, pH 8.3, 192 mM glycine. No methanol.	30 V 90 mA	100 V 350 mA
Isoelectric Focusing, Native Gels, Basic Proteins, Acid Urea Gels		
0.7% acetic acid	30 V	100 V

3.2 The cautions for electrophoresis transfer

The following changes will change resistance and current.

Changes in the preparation of buffer: such as, the SDS ration is increased, ratio of the acid or the alkaline is increased when adjusting the buffer, in this case the strength of ion is changed accordingly.

The PH value, the strength of ion and percentage of acrylamide of gel, especially in the case of gel has not been properly equilibrated.

Quantity of gel: the increased quantity leads to the slight augmented current.

Buffer volume: The increased volume leads to augmented current accordingly.

Quality of platinum electrode: The improved quality of platinum electrode leads to augmented current.

Temperature of transfer: The increased temperature leads to the augmented current.

Time of transfer: The capacity of buffer weakens and the current augments with the running of electrophoresis.

The pre-equilibrium of gel

All the gels should be pre-equilibrium by the transfer buffer before conducting the electrophoresis transfer, which can remove the salt and neutralize the salt which denatures the nucleic acid, otherwise a lot of heat is generated and the conductivity of buffer is increased. Meanwhile, the low concentration gel (<12%) shrinks in the methyl alcohol solution, so the pre-equilibrium activity adjust the gel to the best size eventually before the electrophoresis transfer.

The usage of stirring bar during transfer

All the stirring bar should be put inside Neo-BLOT-Mini-XL during the application of blot in order to stir the buffer in the course of the experiment, which is useful to maintain uniform conductivity of buffer and temperature. It leads to the poor macromolecular transfer and foster the potential safety hazard if the temperature is not adjusted efficiently.

PH value of transfer buffer

Do not adjust the pH value of transfer buffer unless it is necessary. The adjustment of transfer buffer will result in increase of conductivity, which is proved by the output current higher than the expected and decrease of resistance. It is recommended to use electrophoresis power supply and check the initial current value before any electrophoresis.

Recommendation of transfer buffer

Please use the high-quality methyl alcohol. The polluted methyl alcohol will lead to the increase conductivity of transfer buffer and the failure of transfer of macromolecular. Do not reuse or dilute the transfer buffer below the recommended concentration. It is not recommended to reuse the transfer

buffer because the buffer can not maintain a stable pH value during electrophoresis. Diluting the buffer below the recommended concentration will reduce its buffer capacity.

The maximum voltage

The voltage should not exceed the set value mentioned in table 3.1 during the overnight electrophoresis. The conductivity of buffer should be close to the current mentioned in the table. The upper limit of current should be set in electrophoresis power supply. The electrophoresis should be done by the high voltage once the low voltage is not available, however, the time must be shortened otherwise it leads potential safety hazard.

3.3 Formula of buffer

Neo-BLOT-Mini-XL 4-gel Mini Vertical Blot requires around 500ml buffer.

Do not adjust the pH value by increasing the acid or alkali.

- The methyl alcohol should be pure otherwise the metal pollution in the low-purity methyl alcohol will damage the electrode.

Note: Some pH electrodes are not sensitive to Tris, please check whether the pH electrode is suitable for Tris buffer if the pH of the buffer is off. The buffer needs to be formulated again if the pH electrode is right but the pH of buffer is less than 8.

25mM Tris, 192 mM glycine ,20% v/v methyl alcohol, pH 8.3

- Mix 3.03g Tris, 14.4 glycine and 200ml methyl alcohol, add 1 liter of ion-removing distilled water (dd H₂O)

25mM Tris, 192 mM glycine, pH 8.3

- Mix 3.03g Tris, 14.4 glycine, add 1 liter of ion-removing distilled water (dd H₂O)

48mM Tris, 39 mM glycine, 20% v/v methyl alcohol, pH 9.2

- Mix 5.82g Tris, 2.93g glycine and 200ml methyl alcohol, add 1 liter of ion-removing distilled water (dd H₂O)

48mM Tris, 39 mM glycine, pH 9.2

- Mix 5.82g Tris, 2.93g glycine and add 1 liter of dd H₂O

10Mm NaHCO₃, 3 mM NaCO₃,20% methyl alcohol pH 9.9

- Mix 0.84g NaHCO₃ and 0.318g NaCO₃ in the ddH₂O, add 200ml methyl alcohol, and set the volume of ddH₂O to 1 liter.

1.0x TBE (Tri-boric acid EDTA), pH 8.3

- 90mM Tris- boric acid Mm EDTA 5x storage solution
- 54 g Tris alkal
- 27.5 boric acid
- 20 ml 0.5 M EDTA (pH 8.0)
- Add 200ml 5x storage solution into 800ml ddH₂O 1.0x buffer solution

1x TAE (Tri- acetic acid EDTA)

- 40mM Tri- acetic acid 1 mM EDTA
- 50x storage solution
- 242 g Tris alkali
- 57.1 ml glacial acetic acid
- 100 ml 0.5 M EDTA(pH8.0)
- 1x buffer: add 20 ml 50x storage solution until reaching 980ml ddH₂O.

Chapter 4 Procedure for optimizing condition of electrophoresis

4.1 Optimizing protein transfer

Generally speaking, it is difficult for quantitative elution of high molecular weight proteins. The following methods used individually or by combination are useful to improve the transfer rate.

Compositions of different gel

The graded gel makes it easier to elute the protein with wide range of molecular weight than that of the single-concentration gel.

The gel with more pores can be made by decreasing the total concentration of polymer monomer.

The diameter of pore of the gel with 5.26% cross-linking agent methene-bisacrylamide (C %) is shortest regardless of what the concentration of acrylamide is. The resolution is decreased in case of increase of pore diameter caused by the increase or decrease of %C accordingly.

$$C (\%) = \frac{\text{Methyl – bisacrylamide (g)}}{\text{Methyl – bisacrylamide(g) + acrylamide (g)}} \times 100$$

Increase the transfer time

The initial controlling condition determines the total time of electrophoresis transfer. The time ranges from 30 minutes to overnight on the basis of different controlling condition. The voltage of overnight electrophoresis transfer should be set 30V with the view to reduce the heat.

Strengthen the electric field intensity

The setting of initial condition should guarantee the required transfer rate (V/cm) as well as the temperature of transfer. The increased temperature changes the nature of protein and resistance of buffer as well as the field stress. The transfer rate is affected eventually.

Lowering the buffer strength

The diluted buffer lowers the current under the fix voltage and does not cause much more heat in case of higher voltage.

Different buffer and pH

Changing the type of buffer and PH maximizes the ratio of charge to weight. The SDS seems to be separated from protein via ethyl alcohol in the SDS buffer. Assume that the basic protein in the buffer such as Tris, glycine, methyl alcohol, pH 8.3 remains in the condition of equal-neutral-electricity, which makes that the protein can not transferred. Such property applies to the lysozyme. The buffer with pH

9.5 to 10 makes the basic protein, such as lysozyme and histone, transfer better.

Various buffer features different transfer efficiency even in case of similar electric field intensity (V/cm). General speaking, the transfer efficiency of Tris buffer is better than that of acetic acid and phosphate buffer.

Increase the volume of detergent

It is reported by literature that the transfer efficiency is improved by adding 0.1% SDS in the buffer of Tris/ glycine/ methyl alcohol. However, the initial temperature is slightly higher because of the sediment of SDS in case of being under 10°C with the increased current and electric field intensity as well as the heat. The SDS also affects the antigenicity of some protein. In order to elute protein, the SDS is added into the buffer, meanwhile the binding efficiency of protein and nitrocellulose membrane is lowered.

Removing alcohol from buffer

The alcohol in transferring buffer is to improve bending of SDS protein and nitrocellulose membrane. Elimination of alcohol results in transfer efficiency improved but the binding efficiency is lowered. The transfer efficiency is improved on the basic of fact that the alcohol shrinking the pore of gel and the big-sized protein remains inside. The PVDF membrane is applied to eliminate demand of alcohol and create the reasonable strategy for the big-sized protein and hard-transferable protein. The PVDF membrane has to be wetted by 100% methyl alcohol and then put into the buffer without methyl alcohol.

Dealing with limited protease

It is reported in the literature that limited digestion of proteins during the transfer process to enhance the transfer efficiency without decreasing the immunological activity of proteins.

Type of membrane

As said above, the PVDF membrane makes the transfer electrophoresis go under the condition of no methyl alcohol.

Type of gel

If possible, use Non-denaturing gradient gel for separation of the proteins with different molecular weight. The isoelectric focusing gel or native gel are recommended unless the protein sample must be separated according to the molecular weight.

Enhance contact of gel and membrane

The phenomenon that the effective combination of protein molecule and membrane fails because of poor contact of gel and membrane is always treated mistakenly as the futile elution. The poor contact is caused by the surplus liquid between the gel and membrane. The complete contact is done by the technique of employing the test tube and glass bar as the best tool. The good compression can be done

by the suitable filter paper. The gel and membrane should be equilibrated from 30 minutes to 1 hour in the buffer before the electrophoresis is conducted, which prevents the shrinkage and remove the urea and SDS and other reactant from gel during the electrophoresis.

4.2 Optimize DNA and RNA electrophoresis

The problem of elution of nucleic acid can be solved by the adjusting the percentage of gel. The difficulty remained there is large amount of DNA in the quantitative transfer genome. The following methods can be adopted.

Change of gel composition

It is useful for transferring of high molecular weight DNA by lowering the percentage of monomer and cross-linking agent in polyacrylamide and lowering the percentage of agarose gel.

Change of DNA denaturant

The denature of oxalaldehyde allows the elution of DNA more efficient than that of sodium hydroxide. The excellent result can also be achieved by DNA denatured by boiled acrylamide. The polyacrylamide gel would be softened and stuck to membrane by alkaline denaturation.

Chapter 5 Option of transfer membrane

5.1 Protein blot membrane

Nitrocellulose membrane

Nitrocellulose membrane is widely used in protein binding and detection, total protein detection can be done by protein gel dye such as amido black, coomassie blue, ponceau S, fast green FCF etc.) or the more sensitive colloidal gold dye. The nitrocellulose membrane is also used to analyze the radioimmunoassay, fluoroimmunoassay and enzyme-linked immunoassay. The nitrocellulose membrane needs not to be pretreatment because of the binding volume of 80-100 $\mu\text{g}/\text{cm}^2$. The Connected point of specific proteins is easily closed so as to avoid the problem of background. The protein with low molecular weight (less than 20 KD) is easily lost during the washing after electrophoresis transfer, thus, leads to the decreased detection sensitivity. However, the nitrocellulose membrane with the smaller diameter (0.2 μm) of pore can eliminate such phenomenon. The big-molecular (more than 100KD) protein denatured by SDS is hard to be transferred because of the existence of methyl alcohol in the transfer buffer. The methyl alcohol improves the binding of SDS protein and nitrocellulose, meanwhile, it shrinks the pore of gel. The combination is obviously decreased if the methyl alcohol is removed from SDS protein. The transfer rate is increased by adding SDS (until reaching 0.1%) into the buffer, but the binding is decreased. The SDS also enhances the conductivity of current and generates much more heat during the transfer.

PVDF membrane

The PVDF (polyvinylidene fluoride) is the ideal support for amino-terminal sequencing, amino acid analysis, immunoassay of blotted proteins and can reserve the protein in the extreme condition, such as immersed to acid and alkali environment, emerged in organic solvent. The feature of strength is helpful to improve the repeatability and increase the possibility of obtaining the protein with low abundance during the process of sequencing. Besides, the PVDF membrane could improve the binding efficiency in buffer contained SDS. The PVDF membrane must be soaked with 100% methanol before use and then used in a methanol free buffer solution.

5.2 DNA and RNA blot membrane

Zeta-Probe[®] nylon membrane

The nitrocellulose membrane is not suitable medium for nucleic acid electrophoresis transfer because of binding requirement of high concentration salt (>10 x SSC). The nucleic acid with molecular weight $\leq 500\text{bp}$ is impossible to bind even in the condition of high concentration salt. The lower resistance caused by high current going through the high salt solution leads to the high potential current and electrical power that would damage the nitrocellulose membrane under the condition of low voltage.

The invalid transfer would be exist in the required binding because of elution of lowering voltage (V/cm) per centimeter. Zeta-Probe membrane allows all the DNA and RNA with different sizes of chains to bind efficiently in the buffer with low strength ion. As for the nitrocellulose membrane, Zeta-Probe membrane is the ideal option to analyze the nucleic acid because of the stability during the washing after transfer and about ten-fold color reproduction efficiency.

Table 5.1 Guide for protein blotting membrane

There are kinds of blotting membrane for immunoblotting, each of which features the unique advantage according to the specific requirement of different experiments. The physical properties and performance of membrane should be assessed when choosing the most suitable transfer conditions.

Membrane	Pore Size	Binding Capacity ($\mu\text{g}/\text{cm}^2$)	Remarks
Nitrocellulose	0.45 μm 0.2 μm	80–100	Universal protein blotting membrane
Supported Nitrocellulose	0.45 μm 0.2 μm	80–100	Pure nitrocellulose cast on the inert synthetic support to improve the strength and make the operation convenient and the color appears easily.
PVDF	0.2 μm	170–200	Improve the strength and stability for the protein sequencing and blotting. Enhance binding in SDS Immersed by methyl alcohol in advance.
Nylon	0.2 μm	170	The nucleic acid is recommended.

Note: The RNA should not be transferred to nitrocellulose membrane via electrophoresis transfer, instead, the Zeta-Probe membrane must be used.

Chapter 6 Trouble shooting

6.1 Electrophoresis transfer

Poor electrophoresis transfer (detected by staining gel)--Protein

1. Transfer time is too short.

Increase the time of transfer

2. Power is too low.

Always check the current at the beginning of transfer. The specific setting voltage makes the current too low. If the buffer is not formulated properly, the conductivity is too low to lead to shortage of force.

Re-formulate the buffer or increase the voltage.

Try high-strength transfer.

3. Assembly of transfer equipment is incorrect, the wrong direction of protein are moving.

The wrong order of gel and sandwich membrane, or the reversed inserting direction of sandwich clamp in the buffer tank.

4. The charge-to-mass ratio is incorrect

Try the transfer buffer with more acid and alkaline so as to increase the transfer rate of protein, The buffer pH that is closed to iso-electric point of protein makes the transfer fail. It is generally recommended that the buffer pH should be less or more than that of protein by two values of pH so as to increase the transfer efficiency.

5. Protein is precipitating in gel

Have a try to add SDS in the buffer. The SDS could improve the transfer efficiency, meanwhile decrease the binding rate and affect the reaction of certain protein and antibody.

6. The power supply does not work or the improper one was used.

Check the fuse and ensure the output of current and voltage of power supply match the electrophoresis equipment.

7. The methyl alcohol in the buffer is restricting the elution.

The decreased methyl alcohol improves the transfer rate of protein in gel, meanwhile, decreases the binding rate of protein and nitrocellulose membrane as well as PVDF membrane.

8. Gel percentage too high.

Reduce %T (total monomer) or %C (Bis cross-linking agent). 5%C (Bis cross-linking agent)

could make the smallest sized pore, reducing the concentration and enlarge the size of pore so as to improve the transfer rate.

Poor transfer-nucleic acid

1. Gel percentage is too high.

Reduce the percentage of total monomer or cross-linking agent in polyacrylamide gel as well as the percentage of agarose in Sepharose gel.

Before transfer, 0.25M diluted hydrochloric acid was used for cleaving DNA or dilution NaOH for RNA.

2. Transfer time is too short or power conditions are too low.

Increase the transfer time or try high intensity transfer.

3. DNA and RNA can not be transferred to nitrocellulose membrane via electrophoresis because high salting concentrations are required for efficient binding to the membrane.

Use the Zeta-Probe membrane to replace the nitrocellulose membrane.

The warp or lost band: diffusion transfer

1. Poor contact between membrane and gel, the air bubble or surplus buffer remain between imprinting and gel.

Use a test tube or pipette to roll over the surface of membrane in different directions until the air bubble and surplus buffer are removed between gel and membrane so as to ensure the complete contact.

Use thicker filter paper in the gel-membrane sandwich.

Replace the sponges. The sponges would be thin after the long-term squeezing; thus it will not hold the membrane and gel.

2. Power conditions are too high.

Always check the current at the beginning of transfer. The specific voltage leads to the high current. The surplus force would be supplied to electrophoresis cell in case of high current conductivity caused by improper formulation of buffer.

3. The membrane is not immersed completely or has dried out.

White spots on the nitrocellulose membrane indicate the dry areas where protein will not bind. The membrane should be immersed completely and equilibrated by buffer for the usage by heating the distilled water just under the boiling point if the immersed membrane doesn't be wetted immediately in the buffer.

The PVDF membrane should be wetted completely by methyl alcohol before equilibrated in watery buffer because of its hydrophobic property. Please follow the guide of instruction manual.

4. The possible errors in gel electrophoresis

The abnormal electrophoresis may be caused by poor gel binding, improper electrophoresis condition, the polluted buffer, overload of sample etc.

The pattern of gel clamp is transferred on the blotting membrane

1. The polluted or too-thin transfer fiber cushion is used.

Replace the sponge or complete rinse the polluted sponge.

2. There are an excess of protein or SDS in buffer. The protein may penetrate the blotting membrane without binding to it, and dissociate in the electrophoresis cell.

Reduce the amount of protein in the gel and SDS in the buffer. Add a second membrane to binding excessive protein.

3. The transfer buffer is polluted.

Re-formulate the buffer.

Poor binding to the membrane- nitrocellulose membrane

1. The nitrocellulose membrane requires 20% methyl alcohol to optimize protein binding in buffer. Ensure that there is proper methyl alcohol in buffer.

2. The protein may be transferring the nitrocellulose.

The PVDF or nylon membrane (high-combined volume) is recommended, or decrease the diameter of pore of nitrocellulose membrane (0.2 μ m).

Lower the voltage or change it into the standard transfer (if the high-strength transfer is required.)

3. Poor binding of mixed acetate cellulose and protein. The pure nitrocellulose membrane is recommended.

4. Proteins <15000 daltons may show diminish binding to 0.45 μ m nitrocellulose membrane, or may be washed from the membrane during assays.

In order to enhance binding stability, the protein can be crosslinked to nitrocellulose membrane with glutaraldehyde.

The PVDF or nylon membrane with high-binding capacity is recommended.

Use the Tween-20 as the detergent during the process of cleanse and anti-body incubation so as to reduce or remove the condition of strong cleaning.

5. The SDS in the buffer would reduce the binding efficiency of protein. Reduce or remove the SDS from the buffer.

6. Blotting membrane is incompletely wetted.

White spots on the nitrocellulose membrane indicate the dry areas where protein will not bind. The membrane should be immersed completely and equilibrated by buffer for the usage by heating the distilled water just under the boiling point if the immersed membrane doesn't be wetted immediately in the buffer.

Poor binding to the membrane-PVDF membrane

1. Membrane is not wetted completely.

The PVDF membrane should be wetted completely by methyl alcohol before equilibrated in watery buffer because of its hydrophobic property. Please follow the guide of instruction manual.

2. The membrane has dried completely during the operation.

The appearance of complete immersed membrane is gray or semi-transparent.

White spots formed on the membrane indicate that it will be dry. Please re-wet the membrane by methyl alcohol and re-equilibrate membrane by transfer buffer because the protein doesn't binding to the dry points.

6.2 Detection of immunological feature

The high general background

1. Lock condition is not suitable.

The block material must match with the membrane. For example, the degrease dry milk is usually adopted to block the PVDF membrane and nylon membrane fully.

Increase block concentration and the length of time according to the specific requirement.

The block material should be the pure protein. The block material may be polluted by the material that can be combined with nonspecific probe.

2. The rinse project with poor performance is adopted.

Increase the times of washing, length of wash period, or the strength of washing. Use the stronger detergent gradually. The strength of SDS is stronger than that of NP 40 and Tween-20.

3. The blotting membrane is soaked in blotting substrate for a long period.

Remove the blotting membrane from substrate solution when the ratio of info-to-noise can be accepted.

The image should not be excessive, put the blotting membrane in the double-distilled water to stop the reaction.

4. There is pollution in the previous step, such as the step of transfer or the step of electrophoresis.

Discard the gel or buffer.

Replace or rinse the sponge completely. There are an excess of protein or too much SDS in the buffer.

The protein may penetrate the blotting membrane and drift in the electrophoresis cell without binding to the membrane. Reduce the volume of SDS in the gel protein or buffer. Increase the binding of the second membrane and surplus protein.

5. High concentration of primary antibodies or second antibodies.

Increase the dilution of antibody and optimize the working concentration of experiment of mark-blotting.

6. The incubation tray is polluted.

Rinse the tray or use the single-usage tray

There is no specific reaction between binding protein and probe.

1. Primary antibodies or second antibodies are polluted by IgG in non-specific reaction and crossreaction.

Use the purified IgG as primary antibody to adjust the purified blotting-level second antibody.

2. Monoclonal antibody may react non specifically to SDS denatured proteins

Comparing other monoclonal antibodies or polyclonal antibodies

Blotting with non-denatured protein

3. The meaningless mutual action caused by more acidic protein binding to the membrane. Such as antibiotic protein, glycoprotein binding to more acidic protein on the membrane.

Improve the strength of ion in incubation buffer. Increase the times of washing, length of wash period, or the strength of washing. Use the stronger detergent gradually. The strength of SDS is stronger than that of NP 40 and Tween-20. Put Tween-20 in antibody diluent so as to reduce the non-specific binding.

No reaction or weak signal

1. Insufficient sample

The sample may be required to be concentrated before its loading. Or use more sensitive detection methods.

2. The antigen binding to the membrane is not enough.

Dye the gel after transfer or assess the transfer efficiency by pre-dye. Please refer to the previous chapters to improve.

3. Either primary antibody or second antibody is inactivated or unsaturated.

The storage condition of reagent must meet the requirement. Avoid multigelation, bacterial pollution and heat inactivation.

The detergent affects the antibody activity. Remove the detergent from system except block washing.

Optimize the concentration by spot-blotting experiment if the efficiency of antibody is too low.

Increase the period of antibody incubation.

4. Enzyme compound is inactivated or unsaturated.

Detect the activity of reagent (refer to the below table).

The storage condition of reagent must meet the requirement. Avoid multigelation, bacterial pollution and heat inactivation.

Sodium azide is an effective inhibitor of horseradish peroxidase. Use Thimerosal sodium thiosalicylate (Thimerosal) as antibacterial agent.

The impure water will also cause enzyme deactivation, use distillation deionized water completely.

Optimize the concentration by spot-blotting experiment if the efficiency of enzyme compound is too low.

5. Chromogenic reagent inactivation.

Detect the activity of reagent (refer the following info), re-formulate if it is required.

Detect the activity of detection reagent

1. Activity detect of colored solution

The chromogenic reaction is triggered once mixing 1.0ml chromogenic liquid with second antibody compound. The chromogenic reagent is inactivated if the color is not changed after several minutes, thus to re-formulate the reagent.

2. Activity detect of coenzyme solution

Mix 1.0ml of color solution with 1.0ml 1"3000 diluted coenzyme solution. The light blue light appears within 15 minutes. There are some problems with the coenzyme solution if the light does not appear. Re-experiment with fresh coenzyme solution.

3. Activity detect of primary antibody

Test the reaction of antibody and antigen by ELISA, radioimmunoassay, double immunodiffusion, method of precipitation. If possible, try to use the primary antibody with different dilution rate to repeat the experiment.

6.3 Detection of protein

Colloidal gold TP dye- high background

1. Insufficient or missing block steps

Use 0.3% Tween-20 TBS to block 3 times with each 20 minutes.

2. The membrane is not suitable for this dye

The nylon membrane with positive charge can not be used for colloidal gold dye, replaced by the biotin-blotting TP detection.

3. It is polluted in the previous step. Such as the step of transfer or electrophoresis.

Discard the gel and buffer.

Replace or completely wash the sponge.

4. There is excessive protein on the gel or too much SDS is mixed in buffer.

The protein may penetrate the blotting membrane without binding to it, and dissociate in the electrophoresis cell.

Reduce the protein in gel and SDS in buffer. Increase the binding of surplus protein with second membrane.

5. The colloidal gold dye solution was contaminated.

The dye reagent can be recycled. Store the used reagent in independent, clean and plastic container and put the container in the refrigerator. Discard the reagent that sticks to the bottom of the bottle. If the solution is light blue but not the deep red wine color, the solution is contaminated by the salt in buffer. The salt in the buffer reacts to the gel in the golden solution and cause the non-specific sediment of reagent on the membrane. Just discard them.

Colloid gold TP dye-low low sensitivity

1. Increase the incubation period of low-testing signal.

Try overnight incubation, the background signal is strengthened accordingly.

2. The transfer is not done.

Refer to the relative chapter about the content of failure to improve the efficiency of transfer.

3. The period of dye is too long and the deep red wine color is lost to prove that the dye is invalid.

Discard reagent.

4. The salt contaminated in the buffer, the deep red wine color is replaced by the light blue.

Discard the reagent.

5. The sample volume is too small (compare with the detection reagent)

Test the 10pg protein on each band by gold enhancement kit

Biotin- Blotting TP detection-high background

1. Insufficient block condition

Match the block material with membrane. The nylon requires to be added into several solutions like MPO. Refer to the special detailed information in the biotin-blotting manual.

2. The membrane is left in chromogenic reagent for a long time.

Remove the membrane from chromogenic reagent and transfer it to the distilled water to stop the reaction when the signal appears while the background does not appear.

3. There is excessive protein on the gel or too much SDS is mixed in buffer. The protein may penetrate the blotting membrane without binding to it, and dissociate in the electrophoresis cell.

Reduce the protein in gel and SDS in buffer. Increase the bonding of surplus protein with second membrane.

Biotin- Blotting TP detection-no reaction or weak color

1. Incomplete transfer

Refer to the chapter relate to the content of failure to improve the efficiency of transfer.

2. The sample volume is too small (compare with the detection reagent)

Increase the volume of sample of protein in gel.

3. NHS- inactivation of biotin solution

NHS Biotin is hydrolyzed in an aqueous solution. The temperature of reagent bottle must be adjusted to room temperature before opening it in order to avoid the condensation of water vapor. Use sterile syringes to prevent contamination.

Add boric acid-Tween in NHS-biotin reagent before usage.

4. The competition of biotin reagent and amine in buffer salt.

Washing the membrane completely in boric acid-Tween to remove the residual buffer salt during the transfer and electrophoresis.

5. Inactivation of Avidin-HRP compound

Detect whether the reagent is inactivated or not according to the procedures of activity detection.

6. Inactivation of color solution

Detect whether the reagent is inactivated or not according to the procedures of activity detection.

Anion dye-high background

1. Insufficient decoloration

Increase the time of washing and period of washing in decoloration solution.

2. Concentration of dye solution is too high.

Re- formulate the buffer.

3. The nylon membrane is not compatible with anion dye.

Use the box of biotin-blotting protein detection kit.

Anion dye- low sensitivity

The anion dye can not detect the protein with less than 100ng band.

Use the more sensitive dye. Such as Colloid gold total protein detection or biotin-imprint testing box.

Increase the volume of sample to reach the level of anion dye.